



PUBP 35-12

12 Volt, 35 Amp Hour Battery

PHYSICAL SPECIFICATIONS

Nominal Voltage		12V
Nominal Capacity (20HR)		35Ah
Dimensions	Length	197 +/-1mm(7.76 inches)
	Width	130 +/-1mm(5.12 inches)
	Height	156 +/-1mm(6.14 inches)
	Total Height	180 +/-1mm(7.09 inches)
Weight		Approx. 11.107 kg (24.44lbs)
Standard Terminal		B1-M5 bolt & nut

ELECTRICAL SPECIFICATIONS

Capacity	20 hour rate (1.7A)	35 Ah	Max. Discharge Current (5 sec.)	180A	
	10 hour rate (3.0A)	30.5 Ah		Cycle	14.4 to 15.0V (-30mV/°C)
	5 hour rate (5.4A)	21.6 Ah			Standby
	1 hour (20A)	18 Ah			
Internal Resistance Fully charged battery (20°C, 68°F) 10milliohms					

Dimensions (mm): +/-mm

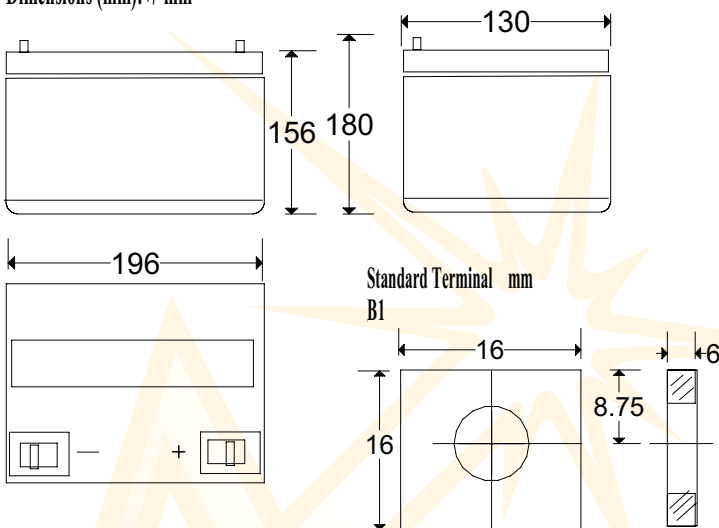

(M5 bolt & nut)

Discharge Characteristics (25 °C, 77 °F)

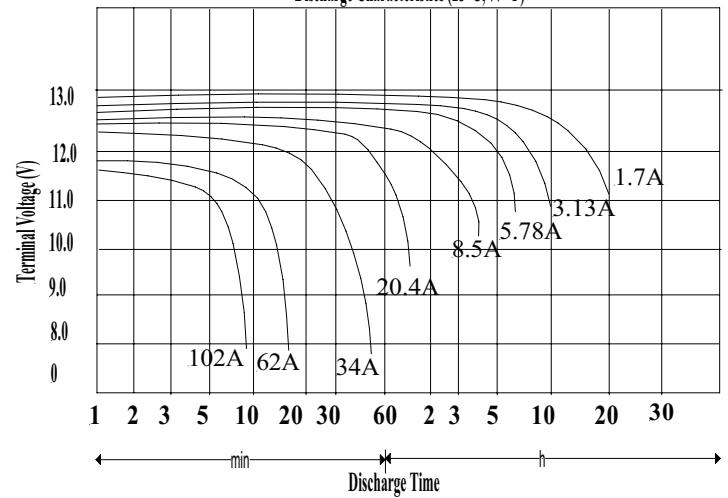

Discharge Characteristics (0 °C, 32 °F)

