

# U-LA

**CUSTOMIZED MOUNTING SYSTEM  
FOR LARGE ARRAYS OF PV MODULES  
USING SOLARMOUNT™ RAILS**



## The Large Array Answer

When you need to design a large array, you can start with a blank sheet of paper and a few volumes of building code ... or UniRac can design and specify a U-LA mounting system for you. Using UniRac saves time and provides you with a low cost, quick installing structure that meets code.

Simply visit the U-LA page at [www.unirac.com](http://www.unirac.com). Download, complete and fax back our **U-LA Large PV Array Design Questionnaire**. We'll evaluate your requirements using our proprietary U-LA system design software.

When your design is complete, you'll receive:

- ① a bill of materials for all required U-LA components
- ② specifications for installer-supplied materials
- ③ a dimensional layout of your system
- ④ a price quote and delivery lead time

This brochure fully illustrates the U-LA and covers the choices raised in the questionnaire. Please call or e-mail us for assistance with any other design concerns.

# U-LA

**CUSTOMIZED MOUNTING SYSTEM  
FOR LARGE ARRAYS OF PV MODULES**



## **From Three Kilowatts to a Megawatt Plus**

U-LA mounting systems can be configured for as little as 3 kW to more than a megawatt of PV modules in an integrated, structurally robust, visually attractive array. Whether on the ground or on a large flat roof, a U-LA mounting system is limited only by the size of the array site itself.

U-LA mounting systems can be designed for

- Landscape or portrait module orientation
- Tilt angles up to 60 degrees
- Winds speeds up to 150 mph (240 kph)
- Seismic Zone 4
- Sloped or irregular topography
- Hard rock to loose soil

## **Quick and Easy Installation—By Design**

Your U-LA system will be as trouble free to install as it is easy to specify. Structural pipes connect with U-bolts, minimizing fabrication on the jobsite. Modules can be mounted to the rails from above or below using mounting slots that accommodate all types of modules. Fabrication on the jobsite is minimized and, if required, is accomplished quickly with standard tools.



**CUSTOMIZED MOUNTING SYSTEM  
FOR LARGE ARRAYS OF PV MODULES**

## Landscape Module Orientation

Used when site layout or array design is optimized with long north-south rows of modules. Generally provides better overall space utilization. Facilitates wiring of long module strings.

Choose landscape mode if you prefer attaching modules to rails before final mounting to the truss structure.

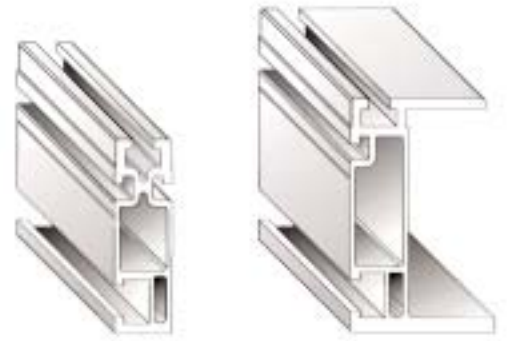

**1 SolarMount Rails**  
Standard Rail (L) HD Rail (R)

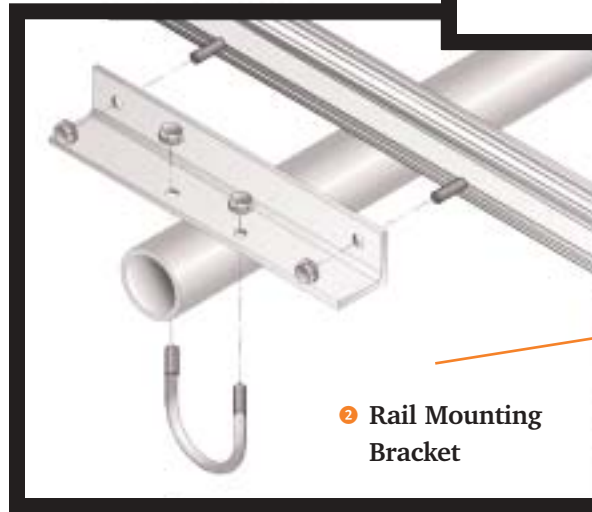

**2 Rail Mounting Bracket**



**4 Sliding Truss Anchor**

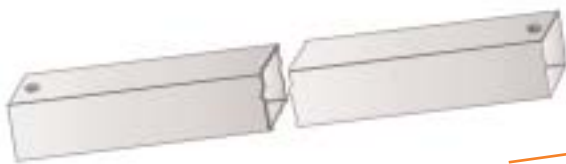

**4 Cross Brace**

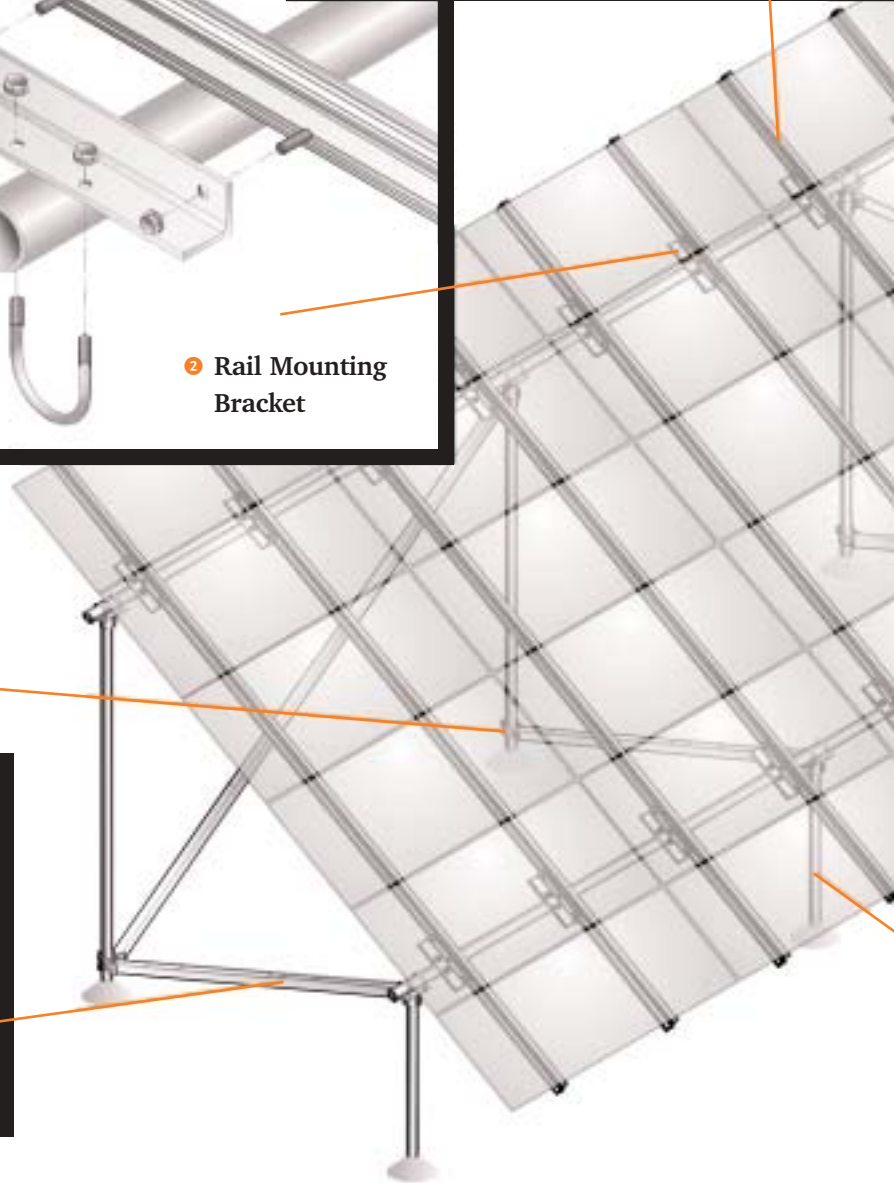

### **1 SolarMount Rails**

Two SolarMount rails are available – Standard and Heavy Duty. Standard rail keeps costs down on smaller

arrays. SolarMount HD rails can be extended up to 25 feet (7.6 meters) with some modules.

### **2 Rail Mounting Brackets**

Fully adjustable brackets ensure easy installation with no fabrication on the jobsite.

## Design Flexibility and Engineering Standards

Each U-LA system is custom designed for each installation. Components are sized for specific site requirements, the physical characteristics of the modules, tilt angle specifications, etc. Complete design docu-

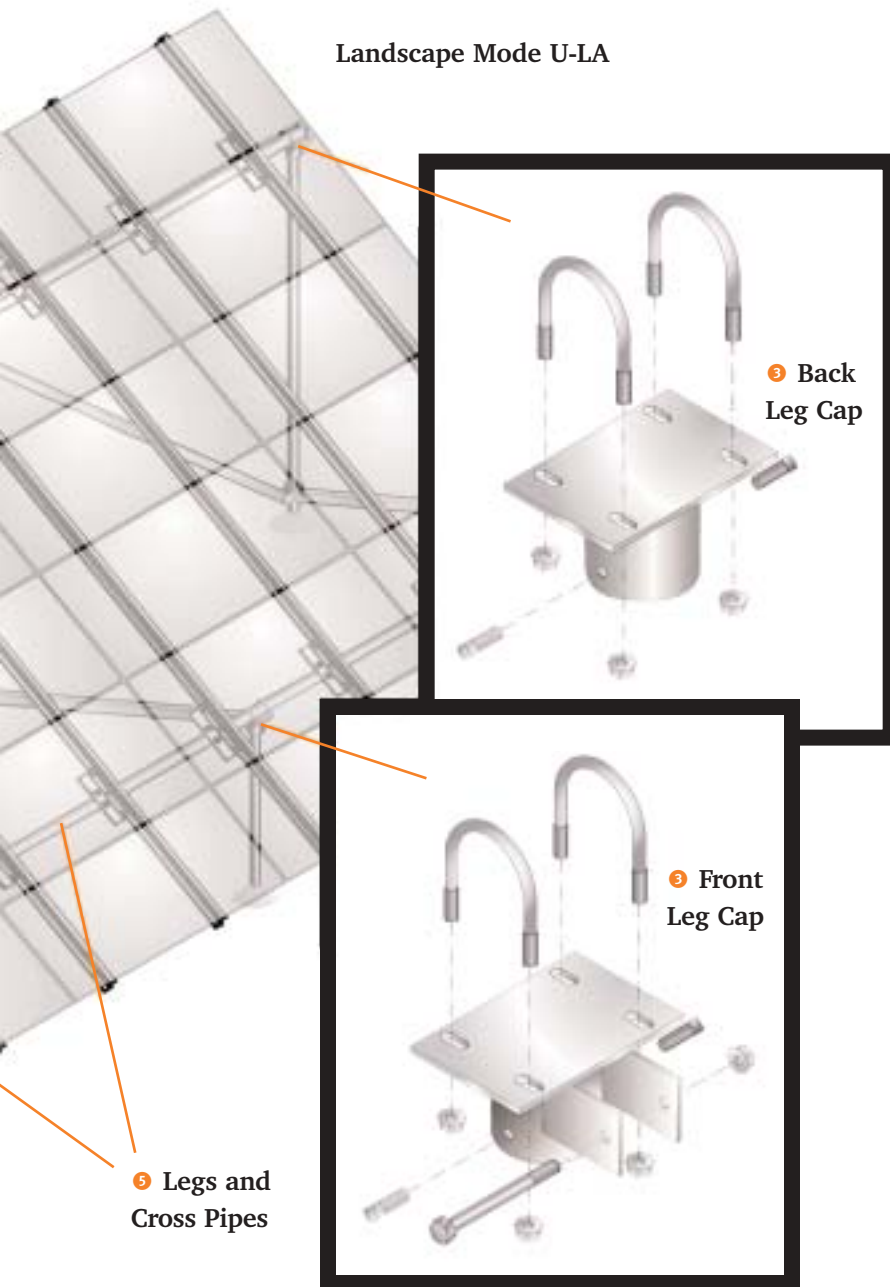

Landscape Mode U-LA

3 Back Leg Cap

5 Front Leg Cap

5 Legs and Cross Pipes



Module Mounting (Landscape Orientation)

Bottom mounting clips (above) employ module mounting holes. They are used when modules are wired and mounted to the rails before fastening to the cross pipes. Top mounting clamps (below) attach with convenient T-bolts. They are usually chosen when the rails are pre-assembled to the cross pipes before module mounting, a common method when installing modules with Multi-Contact® connectors.



### 3 Leg Caps

Dual U-bolts with serrated flange nuts and penetrating set screws provide both quick assembly and structural integrity. Front cap flanges anchor north/south cross brace(s).

### 4 Cross Braces with Sliding Truss Anchors

North-south braces are standard; designs include east-west braces under unusual wind or seismic conditions. Anchors slide for easy installation.

### 5 Legs and Cross Pipes

We specify either 2 or 3 inch Schedule 40 pipe, as needed to meet engineering requirements. It is inexpensive, readily available and easy to work with. Pipe is usually installer

mentation is available for evaluation by building departments and/or engineering professionals. All U-LA system components have been destructively tested to confirm that they meet or exceed

our design standards. U-LA systems conform to applicable Uniform Building Code standards when installed in accordance with our U-LA installation manual.

## Portrait Module Orientation

Can simultaneously accommodate high tilt angles and wind loads. Also used when the array must be below a roof parapet. Limited to four modules north/south, depending on tilt angle.

### 5 Legs and Cross Pipes

### Module Mounting (Portrait Orientation)

A single SolarMount rail runs north/south between the long side of the modules and is fastened to both.

Modules attach to a shared bracket using standard module mounting holes. The bracket attaches to the top slot of the rail.

Portrait Mode U-LA

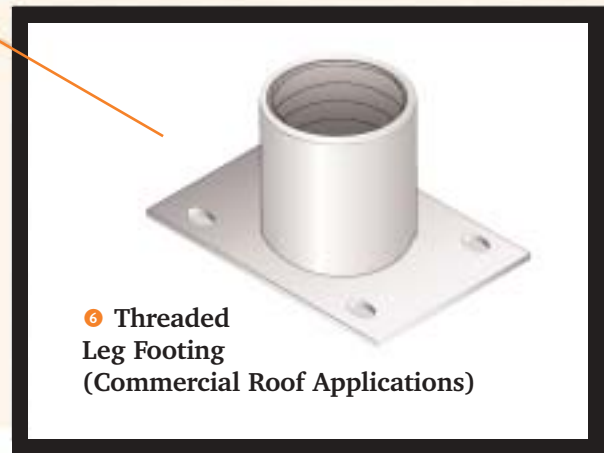
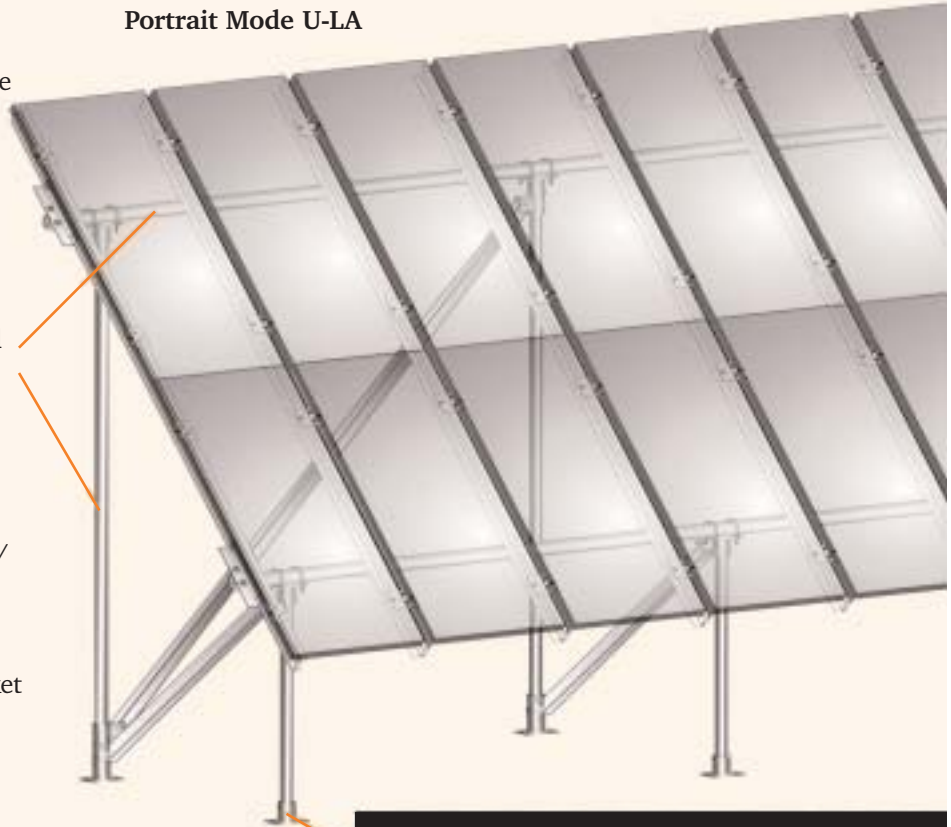

### 6 Threaded Leg Footing (Commercial Roof Applications)

## 6 Secure Footings

supplied. For projects requiring the “kitting” of all components by UniRac, we can supply pipe cut to size and, where required, welded and/or threaded.

Ground mounted U-LAs typically rise from in-ground concrete pillars (see landscape illustration). On roofs or concrete pads, threaded footings secure legs (see portrait

illustration). On flat roofs, footings are typically fastened to stringers that run perpendicular to the roof beams.



**CUSTOMIZED MOUNTING SYSTEM  
FOR LARGE ARRAYS OF PV MODULES**

## PV Module Compatibility List

Call UniRac or your PV dealer for any module not listed.

|            |                                    |
|------------|------------------------------------|
| Astropower | APi100, APi110, APi165             |
| BP Solar   | 3125, 3150, 3160, 4150, 4160, 4170 |
| Isofoton   | Call for specific modules          |
| Kyocera    | KC120, KC125G, KC158G, KC167G      |
| Photowatt  | PW1250, PW1650                     |
| RWE Schott | ASE300                             |
| Sharp      | NE-165U1, NT-175U1, NT-185U1       |
| Shell      | SM110, SQ140, SQ150, SQ160         |
| SunWize    | SW115, SW120                       |
| UniSolar   | US64                               |

## Building Code Compliance

U-LA mounting systems are designed to comply with the Uniform Building Code, 1997, Chapter 16, when installed in accordance with UniRac's U-LA installation manual.

[www.unirac.com](http://www.unirac.com)

## U-LA Component Specifications

**SolarMount** rails, brackets, and cross braces: 6105-T5 aluminum extrusion.

Pipe Connectors and Truss Sliders: Service Condition 4 (very severe) zinc-plated, welded steel.

Fasteners: 304 stainless steel.

Legs and Cross Pipes: ASTM A53B 2-inch or 3-inch Schedule 40 galvanized steel.



**UniRac, Inc.**  
info@unirac.com

3201 University Boulevard SE, Suite 110  
Albuquerque NM 87106-5635 USA

**505.242.6411**  
505.242.6412 Fax

Pub 040312.1ds • April 2004  
©2004 UniRac, Inc. All rights reserved

**10 year limited Product Warranty, 5 year limited Finish Warranty**  
UniRac, Inc., warrants to the original purchaser ("Purchaser") of product(s) that it manufactures ("Product") at the original installation site that the Product shall be free from defects in material and workmanship for a period of ten (10) years, except for the anodized finish, which finish shall be free from visible peeling, or cracking or chalking under normal atmospheric conditions for a period of five (5) years, from the earlier of 1) the date the installation of the Product is completed, or 2) 30 days after the purchase of the Product by the original Purchaser of the Products ("Finish Warranty"). The Finish Warranty does not apply to any foreign residue deposited on the finish. All installations in corrosive atmospheric conditions are excluded. The Finish Warranty is VOID if the practices specified by AAMA 609 & 610-02 - "Cleaning and Maintenance for Architecturally Finished Aluminum" (www.aamanet.org) are not followed by Purchaser. This Warranty does not cover damage to the Product that occurs during its shipment, storage, or installation. This Warranty shall be VOID if installation of the Product is not performed in accordance with UniRac's written installation instructions, or if the Product has been modified, repaired, or reworked in a manner not previously authorized by UniRac IN WRITING, or if the Product is installed in an environment for which it was not designed. UniRac shall not be liable for consequential, contingent or incidental damages arising out of the use of the Product by Purchaser under any circumstances. If within the specified Warranty periods the Product shall be reasonably proven to be defective, then UniRac shall repair or replace the defective Product, or any part thereof, at UniRac's sole discretion. Such repair or replacement shall completely satisfy and discharge all of UniRac's liability with respect to this limited Warranty. Under no circumstances shall UniRac be liable for special, indirect or consequential damages arising out of or related to use by Purchaser of the Product. Manufacturers of related items, such as PV modules and flashings, may provide written warranties of their own. UniRac's limited Warranty covers only its Product, and not any related items.