

GEPV-072

72 WATT PHOTOVOLTAIC MODULE

FEATURES

- 36 single-crystal cells connected in series
- Peak power of 72 Watts at 17.0 Volts
- Designed for optimum use in off grid battery charging applications
- 25-year limited warranty on power output, 5-year limited warranty on materials and workmanship*
- Junction box is conduit ready with terminal strip connectors

BENEFITS

- Output power tolerance of +/- 5%
- Robust lightweight anodized aluminum frame with pre-drilled holes for quick installation
- Engineered for the most rugged of locations including those which experience hail, snow, and ice storms

CERTIFICATIONS

The GEPV-072 Module meets the following requirements:



UL-1703



IEC-61215



*Refer to GE Energy Product Warranty for specific details



imagination at work

PHYSICAL CHARACTERISTICS

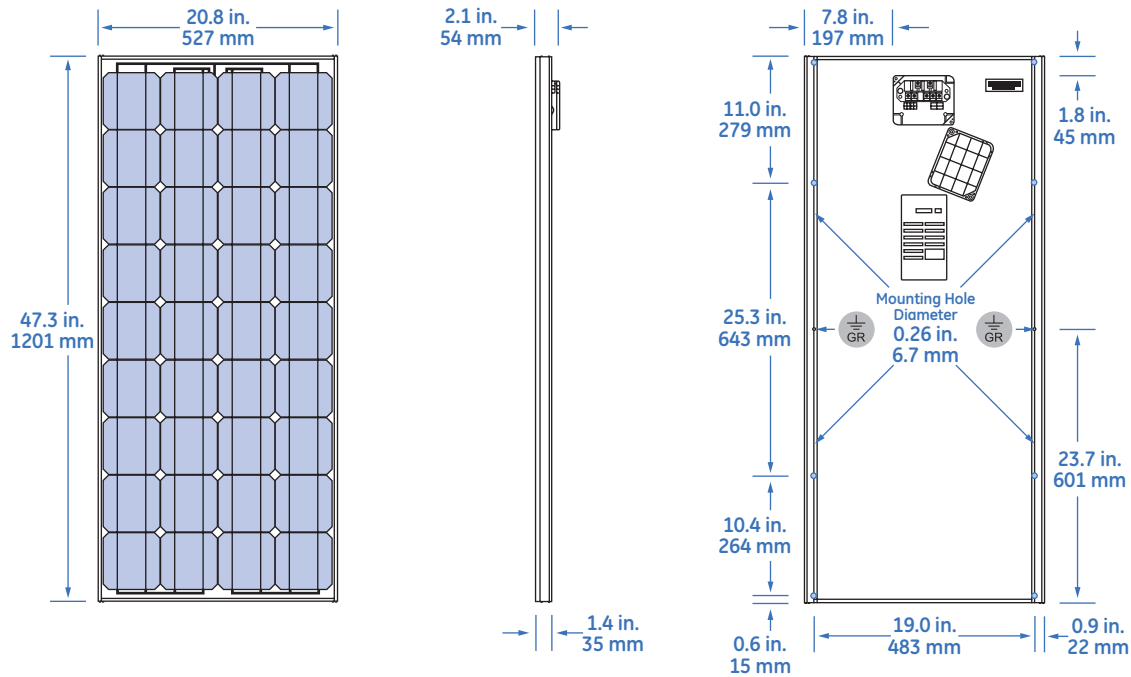

Physical Design Properties

Weight	18.1 lb [8.2 kg]
Weight (Wind) Bearing Potential	50 lbs/ft ² [125 mph equivalent]
Hailstone Impact Resistance	1" @ 50 mph [25 mm @ 80 kph]

ELECTRICAL PERFORMANCE

Typical I-V Curve for GEPV-072 Module

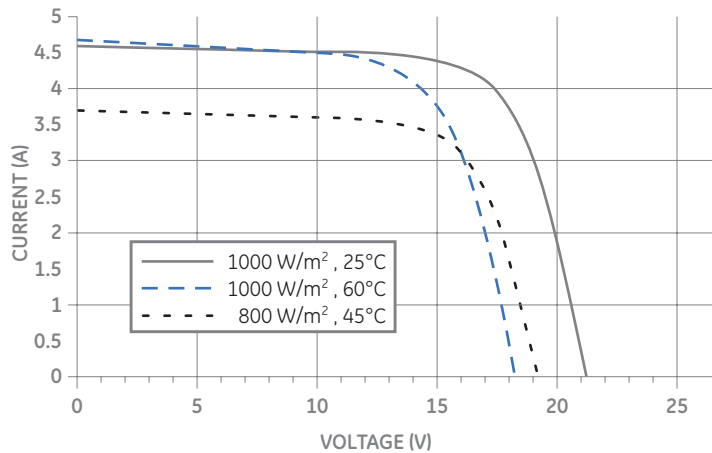

Typical Performance Characteristics

Peak Power (Wp)	Watts	72
Max. Power Voltage (Vmp)	Volts	17.0
Max. Power Current (Imp)	Amps	4.4
Open Circuit Voltage (Voc)	Volts	21.0
Short Circuit Current (Isc)	Amps	4.8
Short Circuit Temp. Coefficient	mA/°C	+2
Open Circuit Voltage Coefficient	V/°C	-0.08
Max. Power Temp. Coefficient	%/°C	-0.5
Max. Series Fuse	Amps	10
Normal Operating Cell Temperature [NOCT]	deg. C	45

I-V parameters are rated at Standard Test Conditions (Irradiance of 1000 W/m², AM 1.5G, cell temperature 25°C). As with all single-crystal PV Modules, during the stabilization process that occurs during the first few days in service, module power may decrease approximately 3% from typical maximum power due to a phenomenon known as Light Induced Degradation (LID). All measurements are guaranteed at the laminate leads. NOCT is defined as 800 W/m², 20 deg. C ambient, and 1 m/s windspeed.



GE Energy
231 Lake Drive
Newark, DE 19702
866-750-3150

gepower.com/solar